



TANNERY MAKING PLANTS.

Leading Provider of Tannery Total Solutions

## 816 Hydraulic Through Feed Sammying Machine



L.H. Side view.

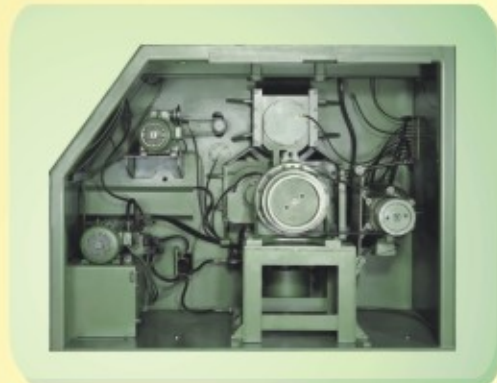

R.H. Side view.



Back view.

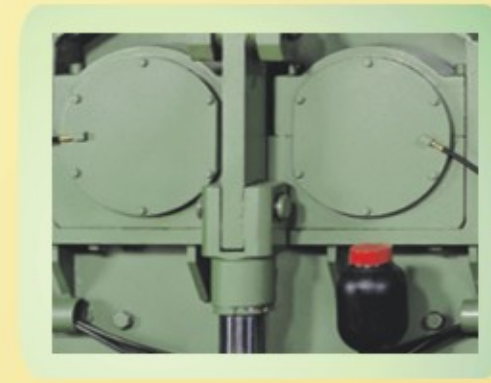

Easy change felts



Control Panel



**3H**  
Since 1971

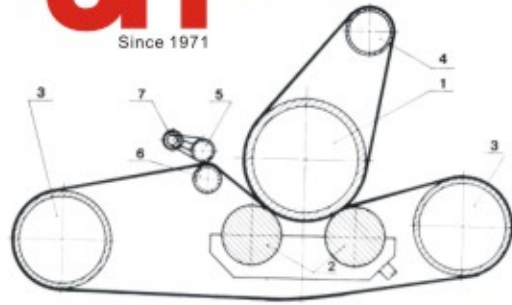

1. Top Pressure Rubber Roller.(600mm O.D)
2. Bottom Pressure Roller.
3. Bottom Tension Roller.
4. Top Tension Roller.
5. Blades Stretching Cylinder.
6. Stretching Support Roller.
7. Stretching Roller variable speed Motor.

Through feed sammying machine on the market now have mainly been developed to increase productivity, to reduce the physical strain of the operators, to make perfect stretch of the leather and to reduce possible wrinkles on hides.

**The most important features of 3H No. 816 Hydraulic through-feed sammying machines as followed:**

- Smooth passage with the least possible wrinkles.
- The speed of passage is adjustable 7 & 15m/min.
- A large diameter high pressure special rubber roller avoids pleating during the feeding in towards the pressure section and keeps the felt band long life.
- The construction allows replacing the felt conveyor within a minimum of time. Neither the rollers nor heavy machine parts have to be removed. The machine is easy to be serviced and has only a few lubrication points hydraulic needs no service at all. All the rollers are running in double rolling bearing, which are packed according to the requirements.
- The collecting basin for liquid, well arrange within guarantee an installation even in dry rooms.
- The running-in area is equipped with a safety device, which stops the machine immediately when being pushed.
- On the feeding-in side locked safety switches are installed to effect a stop of the machines when set going.
- With excellent processing quality, perfect stretching of the leather, simple maintenance, long lasting felts which are easy to change.
- With extremely strong and compact steel structure.
- Stretching roll with perfect stretching of leather and reduce wrinkles on hides and timed automatic return to resting position.
- Stretching roller with stainless steel blades having special design profile.
- Automatic center device system for felt conveyor
- All transmission rollers in plastic reinforced by fiber glass, to guarantee long life.
- Hydraulic control box with special high pressure pump and hydraulic accumulators, guaranteeing a constant and even working pressure.
- The machine can be used in continuous connection for splitting and cleaving.
- The total pressure is infinitely adjustable: 0-60 Tons.
- Plastic sheet on bottom felt & auto return device can gain excellent spreading result, sure no wrinkle on hides.

**Technical Data**

Working width	3000mm
Attendance	2 operators
Output per hour abt.	300 sides or 180 hides
Feed speed (speed variation)	7 & 15 m/min
<b>Power required</b>	
Mini motor	15Kw (20 HP)
Hydraulic unit	1.5Kw (2 HP)
Setting cylinder	1.5Kw (2 HP)
Compressor	0.75Kw (1 HP)
Total require	18.75Kw (25 HP)
Total pressure	60000 kgs
Floor space required,abt. (Mm)	4700 x 2500
Net weight.	12000 kgs
Gross weight abt.	12600 kgs
Seaworthy volume	25.5 CBM
In addition for felt conveyor replacement provided free space	4000mm

**3H MACHINE CO.,LTD.**

WEB :<http://www.3hmachine.com>

E-MAIL :[h3h3h3h@ms24.hinet.net](mailto:h3h3h3h@ms24.hinet.net)

No.190.Yujhong Rd.,East District,Tainan City 701,Taiwan

TEL :+886-6-3312207 FAX :+886-6-3312285

MOBIL PHONE :+886-933-665555

**3H**  
Since 1971

**TANNERY MAKING PLANTS.**

**Leading Provider of Tannery Total Solutions**



**816**

**Hydraulic Through Feed Sammying Machine**